



SHOMAL Engineering & Manufacturing Co. (PIROOZ)

ماشین سازی شمال پیروز

Safety maintenance and operating instruction

LJB 1 & LJB 2/D/W

Explosion protected terminals and Switchgear boxes

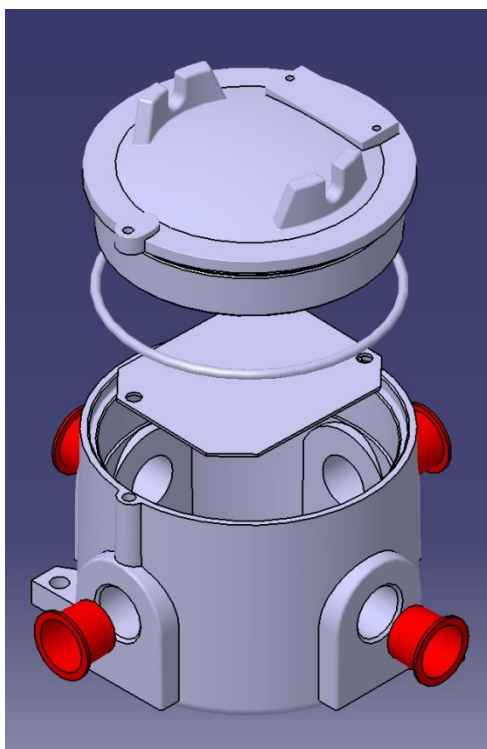

Document number: WI-14(PCD-P-01)/03

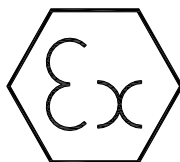

THIS GUIDE SHOULD BE READ CAREFULLY BEFORE INSTALLATION.
INCORRECT INSTALLATION AND USE OF THE JUNCTION BOXES CAN INVALIDATE THE GUARANTEE!

DIMENSION. FIGURE 1

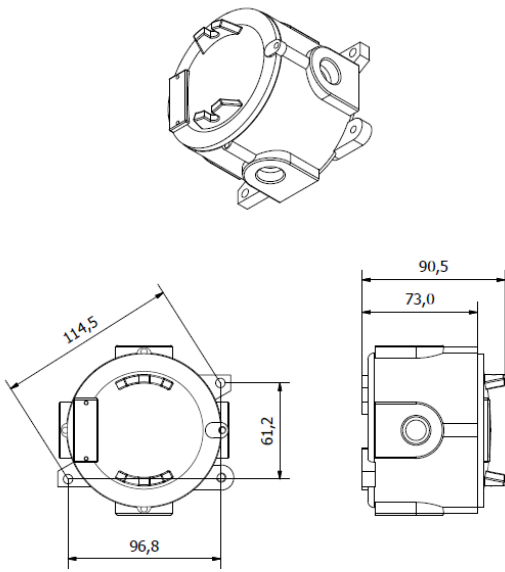

LJB1

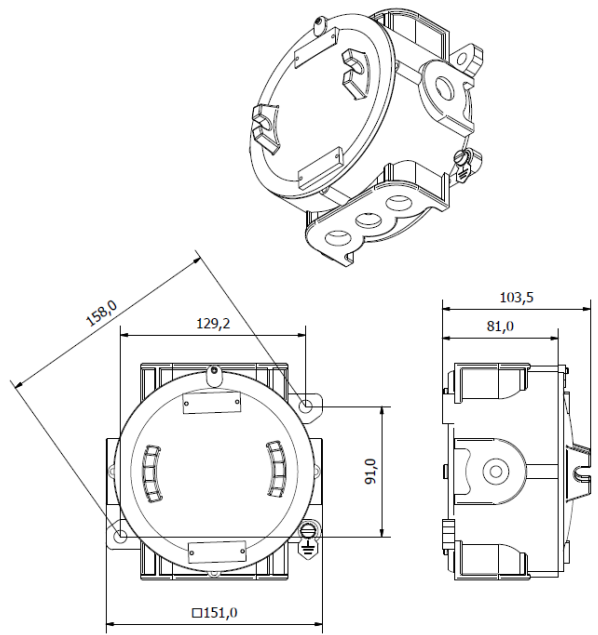

LJB2

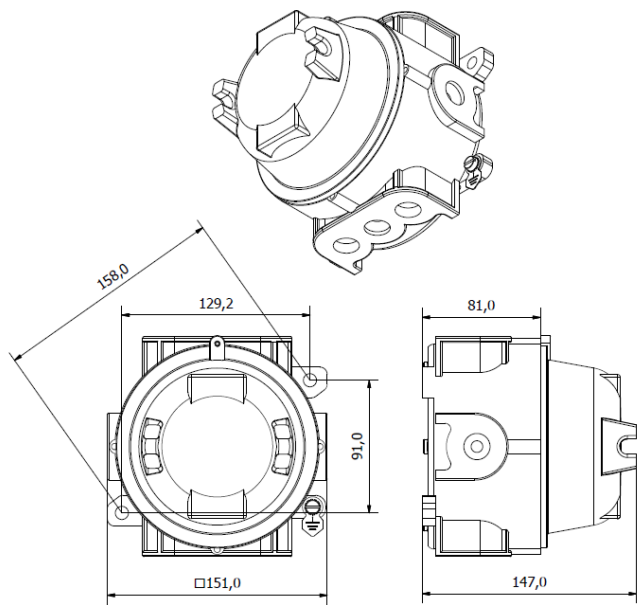

LJB2D

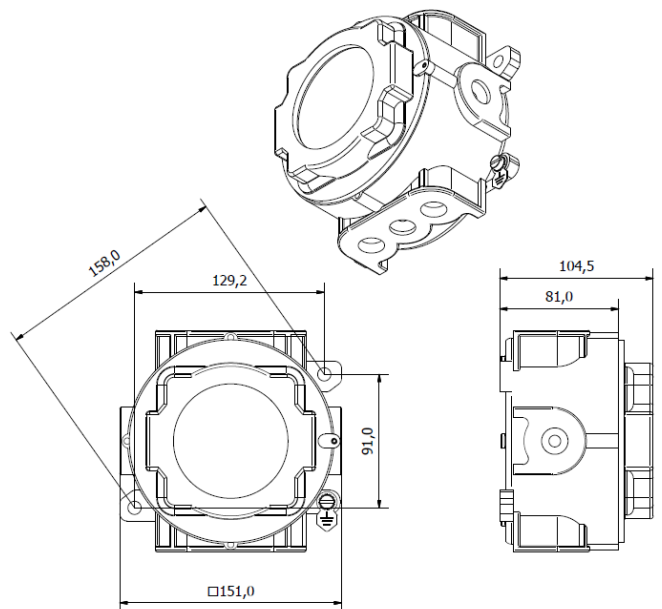

LJB2W

TYPES OF LJB2

- LJB2: The common form of LJB2
- LJB2D: LJB2 with doom door
- LJB2W: LJB2 with glass window door

PORTANT NOTES:

- 1) THIS GUIDE SHOULD BE READ CAREFULLY BEFORE INSTALLATION.
- 2) INCORRECT INSTALLATION AND USE OF THE JUNCTION BOXES CAN INVALIDATE THE GUARANTEE.

Table 1:

TYPES CONFIGURATION

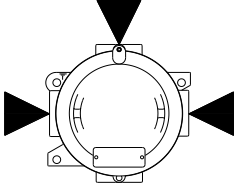
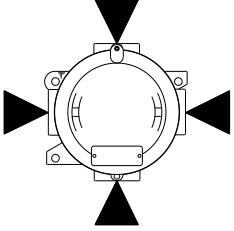
Type	Style	Entries	Volume < 2L
LJB1 T1		3 * 1/2" (M20)	
LJB1 T2		3 * 3/4" (M25)	
LJB2/D/W T1		3 * 1/2" (M20)	
LJB2/D/W T2		3 * 3/4" (M25)	
LJB2/D/W T3		3 * 1" (M32)	
LJB1 X1		4 * 1/2" (M20)	
LJB1 X2		4 * 3/4" (M25)	
LJB2/D/W X1		4 * 1/2" (M20)	
LJB2/D/W X2		4 * 3/4" (M25)	
LJB2/D/W X3		4 * 1" (M32)	

*Other thread forms are available on request. ie. Metric, PG, NPT...

**Other configurations are available on request. Max. number of entries for LJB1=4 Max. number of entries for LJB2=8

***The cable entry holes must be fitted with suitably certified cable glands or suitably certified stopping plugs, which are capable of maintaining the IP66 rating of the equipment.

Table 2:

APPLICATIONS

Max. Number of terminals	Size	V _{Max}	I _{Max}	Max. rail length	Type of enclosure
10	2.5 mm ²	<750 V	<20A	45 mm	LJB 1
7	4 mm ²		<32A		
4 *	6 mm ²		<40A		
20	2.5 mm ²		<20A	82 mm	LJB 2/D/W
15	4 mm ²		<32A		
13	6 mm ²		<45A		
4*	6 mm ²		<40A		
10	10 mm ²		<60A		

* Pillar or column terminals

Table 3:

Component type

Component type	Characteristics	Mounting	Type of enclosure
Measurement devices (Transformers of measurements)	$I_{max} : < 25/5A$	Base plate	LJB 1,2
Power transformers	$V_{max} : < 690V$, $S: <350VA$	Base plate	
Air breaking apparatus*	$V_{max} : < 690V$, $I_{max}: <25A$	Base plate	
Fuses	$V_{max} : < 690V$, $I_{max}: <25A$	Base plate	
<p>* Relays (non-electronic) and contactors</p> <p>1) Electronic devices ($V_{max}: < 230V$, $I_{max}: <5A$), with capacitors up to $200\mu F$ with discharge Resistance of $T < 3s$, Dissipated P max. $<28W$ for T6/T85°C application.</p> <p>Note: Batteries and cells are not permitted in these enclosures.</p> <p>All internal components shall be installed by the SEMC, not the end user.</p>			

1. Safety Instructions (!)

For skilled electricians and instructed personnel in accordance with national regulation, including the relevant standard and, where applicable, in accordance with EN 60079-17 on electrical apparatus for explosive atmospheres.

- 1.1 The boxes must not be operated in Zones 0 and 20.
- 1.2 The apparatus shall not be used in dust layers > 50 mm to EN IEC 60079-0:2018 & EN/IEC 60079-14:2014
- 1.3 The temperature class and gas group marked on the boxes shall be observed.
- 1.4 The technical data indicated on the boxes are to be observed
- 1.5 Changes of the design and modifications to the boxes are not permitted!
- 1.6 The boxes shall be operated as intended and only in undamaged and perfect conditions.
- 1.7 Only genuine **SEMC** spare parts may be used for replacement.
- 1.8 Repairs that affect the explosion protection may only be carried out by **SEMC** or a qualified “electrician” and will subsequently have to be checked by an “expert” in compliance with the respective national regulation.
- 1.9 Prior to taking boxes into operation, they shall be checked in accordance with the “Taking into operation” of this manual.
- 1.10 Before the initial operation, any foreign matter shall be removed from the boxes.
- 1.11 Do not keep these operating instructions inside the boxes during operation.
- 1.12 In order to prevent the risk of electrostatic charge, the glass of LJB2W shall only be cleaned with damp, non-fibrous (cotton)cloth, or sponge.
- 1.13 **The national safety rules and regulations for prevention of accidents and the following safety instructions which are marked with an (!) in these operating instructions will have to be observed.**

2. Conformity with standards

This explosion protected boxes meets the requirement of EN IEC 60079-0:2018, EN/IEC 60079-1:2014 & EN 60079-31:2014 & IEC 60079-31: 2013. It also complies with the EU Directive for “Apparatus and protective systems for use in explosive atmospheres” (2014/34/EU).

It has been designed, manufactured and tested in accordance to the state of the art and according to DIN EN ISO9001:2008.

The boxes are suitable for use in explosive atmospheres, Zone 1 and 2 acc. to EN/IEC60079-10-1&2:2015. And Zones 21 and 22 acc. EN IEC 60079-0:2018 & EN/IEC 60079-14:2014 and EN 60079-31:2014 & IEC 60079-31: 2013

The relevant code of practice is according to EN/IEC 60079-14:2014

3. Technical data

Field of application

CAT II 2G for use in zone 1 or zone 2. Area as defined in EN/IEC 60079-14:2014.
 CAT II 2D for use in zone 21 or 22. Area as defined in EN IEC 60079-0:2018.

Full equipment

EU type examination certificate	TÜV 11 ATEX 7152 X
Marking acc. to 2014/34/EU directive	II 2 G D Ex db IIC T6, T5 or T4 Gb Ex tb IIIC T85°C, T100°C, T135°C Db
IEC certificate of conformity	IECEX TUR 11.0019 X
Marking acc. to IEC	Ex db IIC T6, T5 or T4 Gb Ex tb IIIC T85°C, T100°C, T135°C Db
Ingress protection	IP66
Material	Light metal
Entries	See table 1
Dimension	See figure 1
Permanent storage temperature in original package	-20°C TO +40°C

Component

EU type examination certificate	TÜV 11 ATEX 7154 U
Marking acc. to 2014/34/EU directive	II 2 G D Ex db IIC Gb Ex tb IIIC Db
IEC certificate of conformity	IECEX TUR 11.0020 U
Marking acc. to IEC	Ex db IIC Gb Ex tb IIIC Db
Ingress protection	IP66
Material	Light metal
Entries	See table 1
Dimension	See figure 1
Permanent storage temperature in original package	-20°C TO +40°C

Table 4- maximum permitted dissipation power

Type of Enclosure	Tamb (-20°C to +40°C)			Tamb (-30°C to +55°C)		
	T4, T135°C	T5, T100°C	T6, T85°C	T4, T135°C	T5, T100°C	T6, T85°C
LJB 1	47 W	26 W	18 W	39 W	18 W	10 W
LJB 2/D/W	70 W	41 W	28 W	57 W	28 W	15 W

4. Installation (!)

The respective national regulations as well as the general rules of engineering which apply to the installation and operation of explosion protected apparatus should be observed. Transport and storage of the boxes is permitted in original packaging only

Opening and closing the boxes (!)

The opening of boxes always shall be without voltage; the boxes are well closed when covers are completely threaded on the boxes enclosure.

Dimensions for mounting: See figure 1

Accessories: See **SEMC**. Catalogue or contact SEMC sales department

Cable entries (!)

Mounting the selected cable entries (e.g. cable glands or seals) according to type and dimensions of the main connection cable, following their manufacturer instructions. The cable entries devices have to be the same protection mode of the enclosure, where they are mounting "Ex db IIC"

The cable entry holes must be fitted with suitably certified cable glands or suitably certified stopping plugs, which are capable of maintaining the IP66 rating of the equipment.

5. Taking into operation

Prior to taking the apparatus into operation, the test specified in the relevant national regulations should be carried out.

Apart from that, the correct functioning and installation of the apparatus in accordance with these operating instructions and other applicable regulations will have to be checked.

Incorrect installation and use of the junction box can invalidate the guarantee.

- The IP rating of the enclosure must be maintained for the area of use, by the use of correct arrangement of Cable /gland /sealing arrangements and in accordance with the installation codes as detailed in EN/IEC 60079-14:2014, and this operating instructions.
- Where other certified components are part of assembly, the user must take in to account any limitations listed on relevant certificates.
- The enclosure shall be maintained at IP 66 suitable sealing washer under the shoulder of the cable gland.
- All unused entry holes must be sealed by a suitable certified stopping plug with the same protection level of the boxes.
- The apparatus must not be modified without reference to SEMC as this will invalidate certification.

6. Maintenance (!)

Observe the national rules applicable to maintenance, servicing, inspection and repairing of apparatus for explosive atmospheres, as well as the general rules of engineering.

For dust explosive application, pay special attention don't have present dust layers above 5mm on side of the apparatus.

Servicing

Before opening the enclosure make sure that the apparatus is disconnected from the supply voltage, or take appropriate protective measures.

The required maintenance intervals depend on the respective application and will therefore have to be determined by the user dependent on the conditions of use.

When servicing, in particular those components that affect the explosion protection, will have to be checked, e.g.:

- The flameproof joints have to be clean, undamaged, without corrosion and perfectly greased.
- Gaskets/O-rings for their perfect conditions.
- Cable entries without corrosion.
- Terminals and blanking plugs for their firm fix.
- For LJB2W, resin around the glass should be checked to be in good condition and glass don't have any crack.

If during servicing it proves that repairs are necessary, the Repair / Overhaul / Modification of this manual will have to be observed.

The flame paths of these apparatus have to be greased permanently in order to ensure protection in front of the corrosion, water ingress and seize-up problems. Cleaning rest of grease and corrosion no using sharp metallic devices who can damage the surface of the joint, and greasing they using appropriate grease thermally and Chemically stable with a drop point > 200°C

Inspection/ Repair / Overhaul / Modification (!)

The national's regulations have to be observed

Repairing

The national's regulations have to be observed. The tasks of repairing have to be made by "qualified" personnel.

Repairs may only be carried out with genuine **SHOMAL** spare parts.

Repairs that affect the explosion protection may only be carried out by **SHOMAL** or a qualified electrician in compliance with the applicable rules.

Modifications to the apparatus or changes of its design are not permitted.

Earth connection

These enclosures have an external earth facility suitable for the largest conductor size used in the box.

- In the case of painted boxes, consideration must be given to the removal of paint e.g. under the earth screw/washers of the box which may lead to corrosion of the enclosure and potential reduction in earth protection. This area following installation must be protected against corrosion.

DISPOSAL / RECYCLING

SEMC cares for the environmental protection and recommends therefore to dispose properly of the packing and wrapping of its goods, according to prescriptions and regulations in force in the destination country. The differential waste disposal strongly recommended. When the apparatus is disposed of, the respective national regulations on waste disposal will have to be observed.