



CABLE GLAND

TYPE 421 FLAMEPROOF



SPECIFICATION

Application	Outdoor and indoor . For use with non - armoured elastomer or plastic insulated cables.
Specification	In accordance with the relevant requirements of BS 6121 type A1F, A 2F and BS 5501 parts 1,5, EN 50014, EN 50018, IEC 60079-0, IEC60079-1
Function	Provides seal on outer sheath of cable.
Seals	The inner seal complies with the pressure test of 30 BAR (450 psi) for two minutes.
Marking/certificate No.	Exd IICIP66/ BAS Ex 98D1133U
Ingress protection	IP 66 to IEC 60529
Material	Brass / Stainless steel
Finish	This gland can be coated or plated to suit the application.
Accessories (Optional)	Shroud for additional protection against onerous weather conditions. Sealing Washer for IP66 rating between gland and the equipment.
	Earth Tag to ensure earth continuity between the gland and the equipment.
	Locknut to secure the gland body to the equipment where entry hole is not tapped.

Gland Size ref.	'T' Entry thread sizes				'U' Thread Length				P	Across flats	Across corners	Cable acceptance details		
	Metric	Imp* (in)	PG	BSPP* BSPT* NPT* (in)	Metric Imp PG	BSPP	BSPT	NPT				Diameter of Outer sheath		
												A Min.	A Max.	
Os	16/20	3/4	11/13.5	1/2	15	15	18.6	19.9	27	25	27.7	3.0	7.6	
O	16/20	3/4	11/13.5	1/2	15	15	18.6	19.9	27	25	27.7	7.5	11.5	
A	20	3/4	16	1/2 3/4	15	15	18.6 20	19.9 20.2	25	30	34.6	11.0	13.5	
B	25	1	21	3/4 1	15	15	20 20	20.2 25	29	36	41.6	13.0	19.2	
C	32	1 1/4	29	1 1 1/4	15	15	20 20	23.7 26	25 25.6	30	46	53.1	19.0	26.2
C2	40	1 1/2	36	1 1/4 1 1/2	15	15	20 20	26 26	25.6 26	34	55	63.5	25.0	31.5
D	50	2	42/48	2	15	15	20	30.3	26.9	61	65	75.1	31.5	44.3
E	63	2 1/2	—	2 1/2	15	15	20	33.6	39.9	59	80	92.4	42.5	54.5

Dimensions in millimeters(except*)

Notes:

* The dimension of cable may vary with manufacturing tolerances. We do advise the actual cable diameter is measured where possible before purchasing Cable Glands.

The recommendations here are given in good faith but SHOMAL can not be held liable for mistakes in selection however caused.

**This dimension is the minimum acceptable.

All information may be revised or changed by SHOMAL at anytime without prior notice or explanation.

CABLE GLAND TYPE 421 FLAMEPROOF

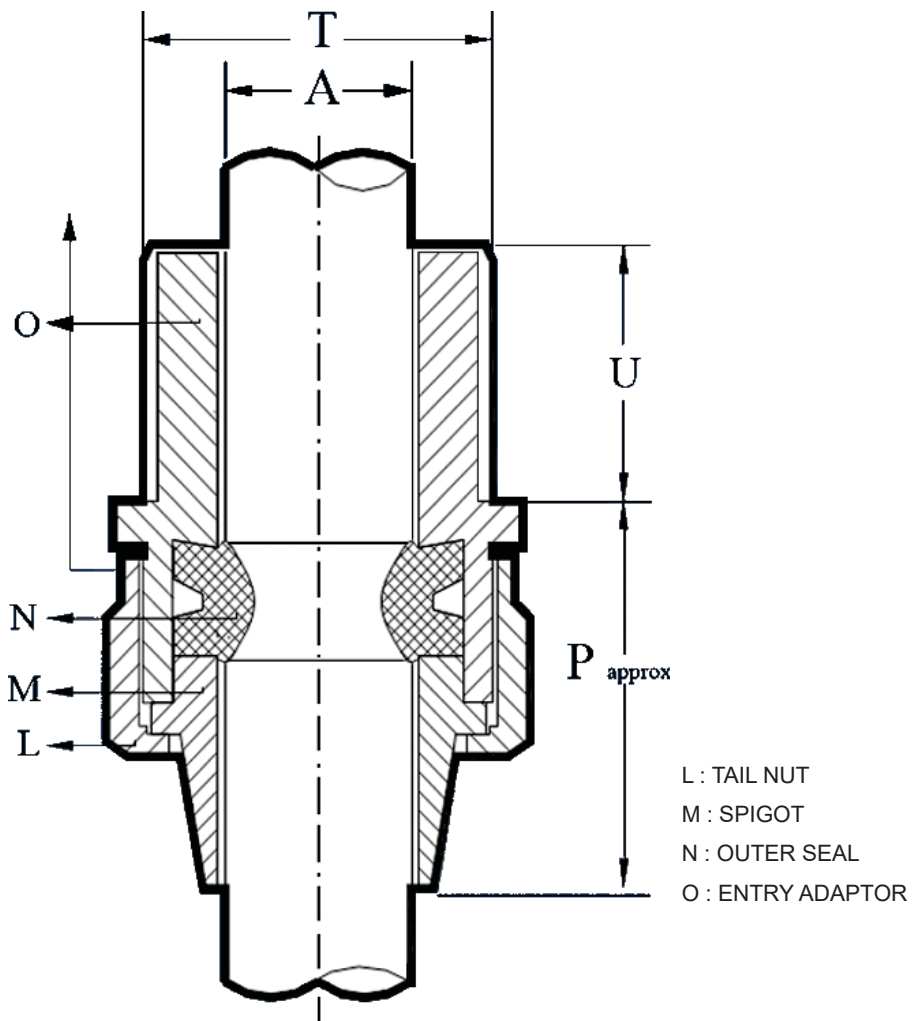

All information may be revised or changed by SHOMAL at anytime without prior notice or explanation.