



SHOMAL Engineering & Manufacturing Co.

ماشین سازی شمال

OPERATING INSTRUCTIONS

MARK SERIES OF STAINLESS STEEL JUNCTION / TERMINAL BOXES TYPES I, II, III, IV, V, VI

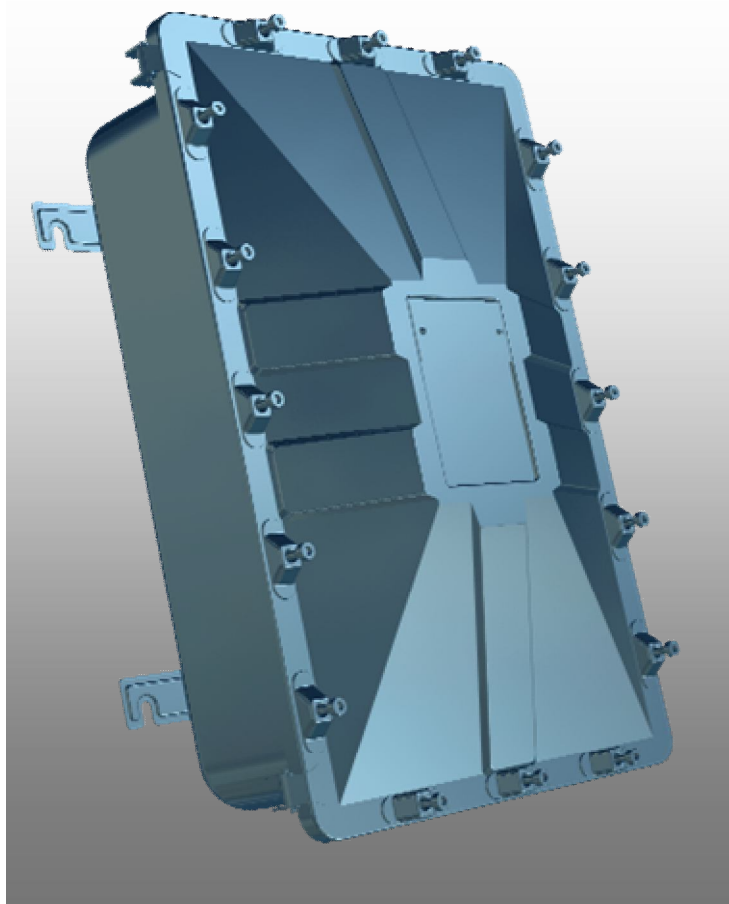

MARK I

Document number: W1-07(PCD-P-01)/02

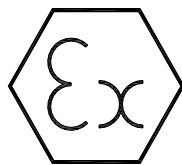

**THIS GUIDE SHOULD BE READ CAREFULLY BEFORE INSTALLATION.
INCORRECT INSTALLATION AND USE OF THE JUNCTION BOXES CAN INVALIDATE THE GUARANTEE!**

**MARK I
DIMENSIONAL DETAILS**

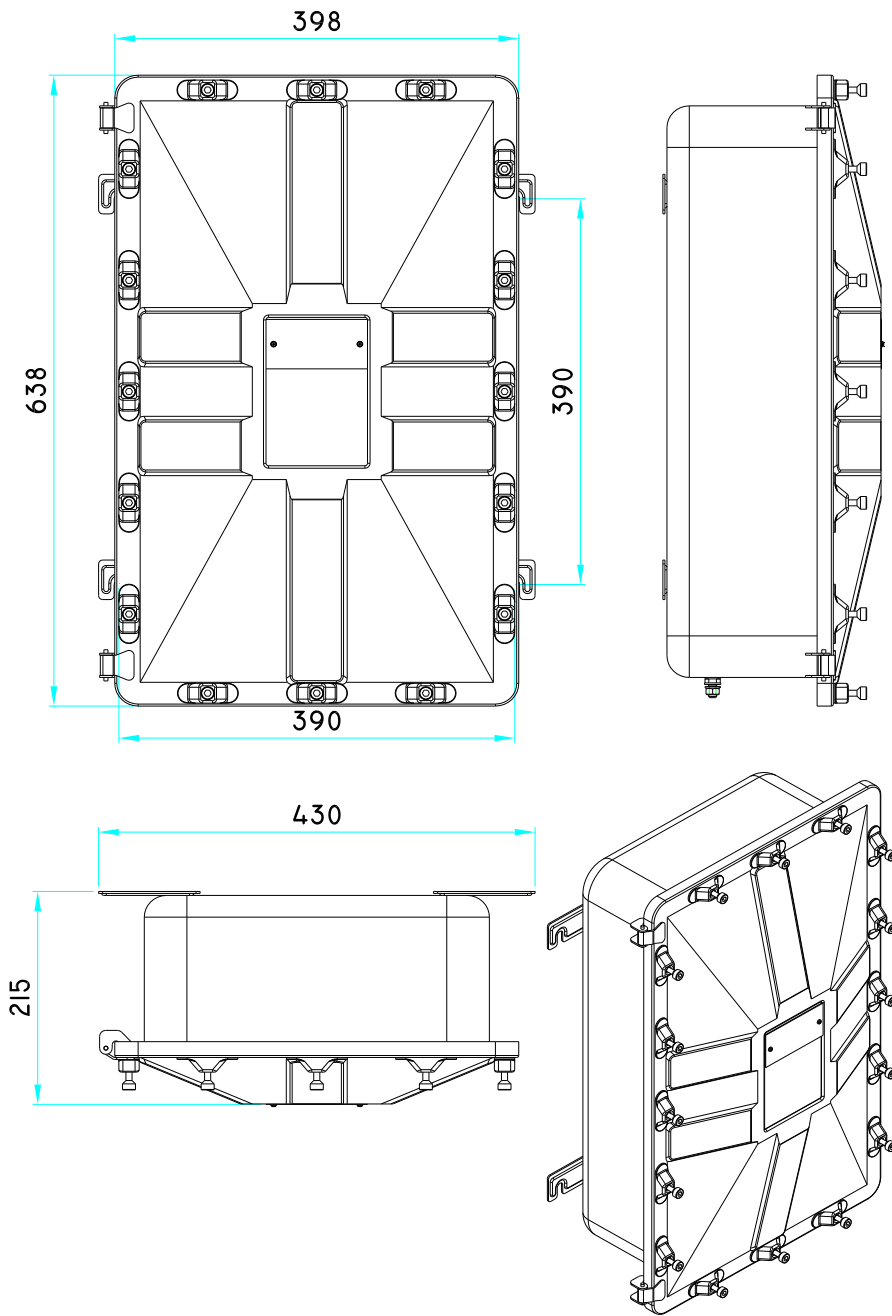

DIMENSIONS (mm)			
	INTERNAL	EXTERNAL	FIXING BRACKETS CENTERS
LENGTH	574±5	638±5	390±1
WIDTH	336±5	430±5	390±1
HEIGHT	160±5	215±5	-

IMPORTANT NOTES:

- 1) THIS GUIDE SHOULD BE READ CAREFULLY BEFORE INSTALLATION,
- 2) INCORRECT INSTALLATION AND USE OF THE JUNCTION BOXES CAN INVALIDATE THE GUARANTEE,

CONFORMITY WITH STANDARDS

THE JUNCTION BOXES MARK I TO MARK VI MEET THE REQUIREMENTS OF THE FOLLOWING STANDARDS::

IEC:	EN:
IEC 60079-0:2007	EN 60079-0:2009
IEC 60079-7:2006	EN 60079-7:2007
IEC 60079-11:2006	EN 60079-11:2007
IEC 60079-31:2008	EN 60079-31:2009

94/9/EC: EQUIPMENT AND PROTECTIVE SYSTEMS INTENDED FOR USE IN POTENTIALLY EXPLOSIVE ATMOSPHERES.

THE JUNCTION BOXES ALSO FULFILL FURTHER REQUIREMENTS SUCH AS THOSE OF THE DIRECTIVE ON ELECTROMAGNETIC COMPATIBILITY (*89/336/EEC*).

THE JUNCTION BOXES HAVE BEEN DESIGNED, MANUFACTURED AND TESTED ACCORDING TO THE *ISO 9001:2008*.

SAFETY INSTRUCTIONS



THE JUNCTION BOXES ARE NOT SUITABLE FOR ZONE 0 AND ZONE 20 HAZARDOUS AREAS. THE TEMPERATURE CLASS AND EXPLOSION GROUP MARKED ON THE JUNCTION BOXES SHALL BE OBSERVED.

THE APPARATUS SHALL NOT BE USED IN DUST LAYERS > 50mm ACCORDING TO *EN 60079-31*.

MODIFICATIONS TO THE JUNCTION BOXES OR CHANGES OF THEIR DESIGN ARE NOT PERMITTED. THEY SHALL BE USED FOR INTENDED PURPOSE AND IN PERFECT AND CLEAN CONDITION.

FOR REPLACEMENT AND REPAIR ONLY GENUINE SHOMAL SPARE PARTS SHALL BE USED. REPAIRS THAT AFFECT THE EXPLOSION PROTECTION MAY ONLY BE CARRIED OUT BY **SHOMAL** OR QUALIFIED ELECTRICIAN IN COMPLIANCE WITH THE RESPECTIVE NATIONAL REGULATIONS.

PRIOR TO TAKING THE JUNCTION BOXES INTO OPERATION, THEY SHALL BE CHECKED IN ACCORDANCE WITH THE "TAKING INTO OPERATION" OF THIS MANUAL. BEFORE THE INITIAL OPERATION, ANY FOREIGN MATTER SHALL BE REMOVED FROM THE JUNCTION BOXES.

OBSERVE THE NATIONAL SAFETY RULES AND REGULATIONS FOR PREVENTION OF ACCIDENTS AS WELL AS SAFETY INSTRUCTIONS INCLUDED IN THIS OPERATING INSTRUCTION.

FIELD OF APPLICATION

- CAT II 2G for use in zone 1 or zone 2. Area as defined in *EN 60079-14*.
- CAT II 2D for use in zone 21 or 22. Area as defined in *EN 60079-14*.

SERVICE TEMPERATURE: -40°C TO +80°C

PERMANENT STORAGE TEMPERATURE IN ORIGINAL PACKAGE:
-40°C TO +80°C

CERTIFICATION MARKING:

Mark I enclosure can be marked as follows:

ACCORDING TO ATEX:

CERTIFICATE NO.: TUV 11 ATEX 7155X

ACCORDING TO IECEX:

CERTIFICATE NO.: IECEX TUR 11.0021X



II 2 GD

Ex e II T6 Gb or Ex e II T6 Gb
Ex ia IIC T6 Gb or Ex ia IIC T5 Gb
Ex t IIIC T80°C Db or Ex t IIIC T95°C Db

TERMINAL BOX WATTAGE FACTOR:

For calculation method for checking terminal capacity vs. maximum permitted power dissipation see page 6 of this manual.

TO OPEN THE LID

1. Disconnect power, (isolate all circuits).
2. Un-tighten all of M8 lid screws.
3. Carefully open the lids on its hinges ensuring the sealing gasket is not damaged or misplaced.

TO CLOSE THE LID

1. Any foreign matter shall be removed from the apparatus.
2. Check that the sealing gasket is secured inside the lid, and undamaged. Make sure that the lid is refitted correctly.
3. Locate and tighten the M8 lid screws using **11** Nm torque for first pass and **16** N/m for final pass. If the screws are over tightened the apparatus can be damaged.

ENCLOSURE INSTALLATION

1. The IP rating of the enclosure must be maintained for the area of use, by the use of correct arrangement of Cable /gland /sealing arrangements and in accordance with the installation codes as detailed in *EN 60079-14*, *EN 60079-31*, and this operating instructions.
2. Where other certified components are part of assembly, the user must take in to account any limitations listed on relevant certificates.
3. If an optional Breather/ Drain as listed in the enclosure certificate is fitted, the enclosure must be sited such that the Breather/ Drain is pointing vertically downwards from it's bottom.
The IP rating of the Breather Drain should match with the IP rating of the enclosure.
4. The enclosure has Metric clearance/plain entry holes as standard. Alternative clearance holes are available. Provided they are to a recognized standard e.g. BSPP, ET etc. (Parallel threads only).
Plain entry holes must maintain the following:
 - a) The plain hole shall be no larger than 0.7mm above the major diameter of the entry thread.
 - b) Glands or stopping plugs shall be secured internally by suitable locknuts, such that they will not be dislodged by a 7Nm impact.
 - c) The enclosure shall be maintained at IP 66 or 68 by a suitable sealing washer under the shoulder of the cable gland.
 - d) All unused entry holes must be sealed by a suitable stopping plug, as listed on the enclosure certificate. The stopping plug shall be held in place by a locknut and also the IP rating of the junction box shall be maintained for zone of use.The apparatus must not be modified without reference to **SHOMAL** Co., as this will invalidate certification.

TERMINAL WIRING (TW)

- a) All wiring must be carried out in accordance with the relevant code of practice and/ or instruction e.g. *EN 60079-14 and EN 60079-31*.
- b) The voltage and current and maximum dissipated power shown on the label must not exceed.
- c) When use as a general purpose junction box or marshaling box the circuits carrying current $\geq 1\text{A}$ shall be individually protected against over current such that the protective device operates effectively at no more than 1.45 times the current carrying capacity of the smallest conductor used in that circuit.
- d) Where a major portion of the terminals are carrying maximum rated current the temperature at the branching point of the conductors may exceed 70°C . Under this circumstances the installer must insure that the limiting temperature for the cable insulation used acceptable e.g. 85°C (T6) or 100°C (T5).
- e) The wiring installation must extend to within 1mm of the metal face of the terminal, unless the relevant certificates allow more. (See terminal schedule for limitations).
All lids must be insulated for the appropriate voltage.
- f) Not more than one single or multiple standard lead shall be connected in to either side of the terminals, unless the relevant component certificate allows more, or unless the multiple conductors have been previously joined in a suitable manner (for example with an insulated crimped boot lace ferrule, mounted in a vertical position) such that they form a single cohesive item for insertion into a terminal way. A parallel shaft screw driver of the correct size should be used.
- g) Only those terminals shown on terminal schedule attached may be incorporated in the box.(see table 3)
The installer must insure that the condition of use for the terminals outlined is complied with.
- h) All terminal screws used and unused shall be fully tightened down.
- i) The installer shall ensure creepage and clearance distance are not reduced, especially between intrinsically safe (is) and non-is circuits (e.g. 50mm clearance).
- j) The use of any cross connection devices between adjacent terminal ways shall be in accordance with the requirements of the relevant component certificate listed on held on.
- k) Use of the terminal box at ambient temperature below -20°C is dependant upon the minimum service temperature of the terminals.
- l) When connecting a terminal with a conductor that is below the maximum cross section area maximum amps/pole must be reduced in line with the maximum amps indicated for the terminal equivalent to the conductor size being fitted e.g. for a terminal that can take a maximum conductor size of 10mm^2 at 50 amps, but is fitted with a 4mm^2 conductor then the current shall be reduced to maximum a 21 amps, or the rating on the junction box lid label (whichever is the lowest).

EARTH CONNECTION

These enclosures have an integral internal/external earth stud assembly suitable for the largest conductor size used in the box.

1. In the case of painted boxes, consideration must be given to the removal of paint e.g. under the earth stud on the inside of the box which may lead to corrosion of the enclosure and potential reduction in earth protection. This area following installation must be protected against corrosion.

TAKING INTO OPERATION

Prior to taking the apparatus into operation, the test specified in the relevant national regulations will have to be carried out.

Apart from that, the correct functioning and installation of the apparatus in accordance with this operating instructions and other applicable regulations will have to be checked.

Incorrect installation and use of the junction box can invalidate the guarantee.

MAINTENANCE / SERVICING

The relevant national regulations which apply to the maintenance/servicing of the electrical apparatus in explosive atmosphere shall be observed.

Before opening the enclosure make sure that the apparatus is disconnected from the supply voltage, or take appropriate protective measures.

The required maintenance intervals depend on the respective application and will therefore have to be determined by the user dependent on the conditions of use.

When servicing the apparatus, particularly those parts that are decisive for the type of protection against explosion, will have to be checked(e.g. intactness of enclosure, cable glands, efficiency of the cover gaskets).

If during servicing repairs prove to be necessary, the Repair / Overhaul / Modification of this manual will have to be observed.

REPAIR / OVERHAUL / MODIFICATION

Repairs may only be carried out with genuine **SHOMAL** spare parts.

Repairs that affect the explosion protection, may only be carried out by **SHOMAL** or a qualified electrician in compliance with the applicable rules.

Modifications to the apparatus or changes of its design are not permitted.

DISPOSAL / RECYCLING

When the apparatus is disposed of, the respective national regulations on waste disposal will have to be observed.

CALCULATION METHOD FOR CHECKING TERMINAL CAPACITY vs. MAXIMUM PERMITTED POWER DISSIPATION

The maximum dissipated power of junction box is given by the following formula:

$$P = R_{tot} \times I^2 \times N$$

Where:

P= Maximum dissipated power in watts.

R_{tot} = Combined Terminal Resistance + Conductor Resistance (See *BS 6360* & table 1 below) in Ohms.

I = Rated Current of Terminal in Amps

N = Number of terminals fitted

The conductor resistance is calculated from the length of conductor used for each terminal within the enclosure, multiplied by the cable resistance as defined by the cable manufacturer.

Typical cable resistances are given in Table 2, but may vary depending on the cable manufacturer.

Terminal resistances are defined in Table 3 as per terminal certification data.

EXAMPLE:

Assume a junction box which has a maximum dissipated power of **8.4W**.

Consider **0.365m** length for its maximum internal linear dimension.

The junction box fitted with **25 SAK 2.5** terminals, operating at **7A** each with **2.5mm²** cable attached:

Resistance of conductor = 0.00741 Ω/m x 0.365 m = 0.0027Ω per conductor

Resistance of terminal = 0.00035Ω

Total resistance per terminal = 0.00035Ω + 0.0027Ω = 0.00306Ω

Therefore $p = I^2 \times R \times N = 7^2 \times 0.00306\Omega \times 25 \text{ terminals} = 3.74W$

Since the maximum permitted dissipated power is measured at 8.4W, therefore the assembly of 25 SAK 2.5 terminals would be acceptable.

TABLE 1

JUNCTION BOX TYPE	MAXIMUM DISSIPATED POWER FOR T5 Tamb=40°C (WATT)	MAXIMUM DISSIPATED POWER FOR T5 Tamb=55°C (WATT)	MAXIMUM DISSIPATED POWER FOR T5 Tamb=65°C (WATT)	MAXIMUM DISSIPATED POWER FOR T6 Tamb=40°C (WATT)	MAXIMUM DISSIPATED POWER FOR T6 Tamb=55°C (WATT)	MAXIMUM INTERNAL LINEAR DIMENSION (meter)
MARK I	41.68	18.09	1.75	18.09	1.75	0.66

TABLE 2

COPPER CONDUCTOR RESISTANCE		
CONDUCTOR CROSS SECTIONAL AREA (mm ²)	RESISTANCE (OHM/m)	RESISTANCE FOR 0.66m CONDUCTOR LENGTH (OHM)
0.5	0.036	0.02376
0.7	0.0258	0.017028
1	0.0181	0.011946
1.5	0.0121	0.007986
2.5	0.00741	0.0048906
4	0.00461	0.0030426
6	0.00308	0.0020328
10	0.00183	0.0012078
16	0.00115	0.000759
25	0.000724	0.00047784
35	0.000524	0.00034584
50	0.000362	0.00023892
70	0.000268	0.00017688
95	0.000189	0.00012474
120	0.000151	0.00009966
150	0.000121	0.00007986
240	0.00007625	0.000050325
300	0.000061	0.00004026

TABLE 3

MARK I TERMINALS DATA						
TERMINAL TYPE	CONDUCTOR SIZE		ATEX CERTIFICATE NO.	MAX AMPS	MAX VOLTS	TERMINAL RESISTANCE (OHM)
	mm ²					
	MIN	MAX				
WDU 1.5ZZ*	0.13	2.5	KEMA 98ATEX1685 U	15	550	0.000862
WDU 2.5/ 1.5 ZR	0.13	4	KEMA 98ATEX1685 U	21	550	0.000654
WDU 2.5	0.13	4	KEMA 98ATEX1683 U	21	550	0.0002
WDU 2.5N	0.13	4	KEMA 98ATEX1683 U	21	420	0.00031
WDU 4	0.13	6	KEMA 98ATEX1683 U	28	750	0.00014
WDU 6	0.5	10	KEMA 98ATEX1683 U	36	550	0.00009
WDU 10	1.31	16	KEMA 98ATEX1683 U	50	550	0.000075
WDU 16	1.5	25	KEMA 98ATEX1683 U	66	750	0.00005
WDU 35	2.5	50	KEMA 98ATEX1683 U	109	750	0.000028
WDU 50N	5.26	70	KEMA 98ATEX1683 U	153	750	0.00005
WDU 70/95	16	120	KEMA 98ATEX1686 U	202	750	0.00005
WDU 120/150	35	150	KEMA 98ATEX1686 U	234	1100	0.00005
WDU 240	70	240	KEMA 01ATEX2186 U	240	750	0.0000276
WDK 2.5*	0.13	4	KEMA 98ATEX1687 U	21	275	0.000862
WFF 35*	2.5	50	KEMA 98ATEX1684 U	150	1100	0.0000384
WFF 70	2.5	95	KEMA 98ATEX1684 U	232	1100	0.00002656
WFF 120	6	150	KEMA 98ATEX1684 U	309	1100	0.00001933
WFF 185	10	240	KEMA 98ATEX1684 U	415	1100	0.00001954
WFF 300	25	300	KEMA 98ATEX1684 U	520	1100	0.00001673
SAK 2.5*	0.5	4	KEMA 97ATEX1798 U	24	500	0.00035
SAK 4	0.5	6	KEMA 97ATEX1798 U	32	800	0.0003
SAK 6N	0.5	10	KEMA 97ATEX1798 U	41	800	0.0002
SAK 10	1.5	16	KEMA 97ATEX1798 U	57	800	0.00004
SAK 16	2.5	16	KEMA 97ATEX1798 U	76	1000	0.000023
SAK 35	6	50	KEMA 97ATEX1798 U	125	800	0.000092
ZDU 2.5*	0.08	4	KEMA 97ATEX2521 U	21	550	0.00065
ZDU 2.5/3AN	0.08	4	KEMA 97ATEX2521 U	21	550	0.00069
ZDU 2.5/4AN	0.08	4	KEMA 97ATEX2521 U	21	550	0.0005
ZDU 2.5/2x2AN	0.08	4	KEMA 97ATEX2521 U	21	550	0.00082
ZDU 4	0.21	6	KEMA 97ATEX2521 U	28	550	0.00041
ZDU 6	0.21	6	KEMA 97ATEX2521 U	36	550	0.00027
ZDK 2.5/1.5*	0.08	2.5	KEMA 97ATEX4677 U	18	275	0.00082
UK 1.5N**	0.14	0.7	KEMA 98ATEX1651 U	17	275	0.0004571
UK 2.5N	0.2	2.5	KEMA 98ATEX1651 U	28	550	0.0004166
UK 3N	0.2	2.5	KEMA 98ATEX1651 U	28	750	0.0005
UK 5N	0.2	4	KEMA 98ATEX1651 U	38	750	0.000375
UK 6N	0.2	6	KEMA 98ATEX1651 U	53	750	0.000158
UK 10N	0.5	10	KEMA 98ATEX1786 U	73	750	0.0001228
UK 16N	0.75	16	KEMA 98ATEX1786 U	88	750	0.000171
UK 35	0.75	35	KEMA 98ATEX1786 U	145	750	0.000088
UKH 50	10	50	KEMA 98ATEX1786 U	135	750	0.0001
UKH 95	16	95	KEMA 98ATEX1786 U	210	750	0.0000646
UKH 150	25	150	KEMA 99ATEX8332 U	265	726	0.00006535
RTP 2.5***	0.5	4	KEMA 04ATEX2265 U	24	500	0.000146
RTP 4	0.5	4	KEMA 04ATEX2265 U	32	500	0.000175
RTP 6	0.5	10	KEMA 04ATEX2265 U	41	800	0.000066
RTP 10	0.5	16	KEMA 04ATEX2265 U	57	800	0.000072
RTP 16	0.5	16	KEMA 04ATEX2265 U	76	800	0.000112
RTP 25	0.5	25	KEMA 04ATEX2265 U	101	800	0.000069
RTP 35	1.5	35	KEMA 04ATEX2265 U	125	800	0.000022
RTP 50	10	50	KEMA 04ATEX2265 U	150	1000	0.000087

* WEDMULLER / KLIPPON SAK & WDU & WDK & ZDU & ZDK &

WFF.

** PHOENIX CONTACT UK & UKH

*** RAAD RTP

RANGE OF TERMINALS ARE COVERED BY COMPONENT CERTIFICATES LISTED IN TABL 3 ALL CODED EExe II.