

JUNCTION BOX

Supreme SERIES

SPM 2



Zone 1,2,21,22



SPECIFICATION

Type	SPM 2
Application	Terminal box or marshaling box
Protection	Ex e IIC Gb- Ex t IIIC Db
Marking (ATEX)	⊕ II 2 GD
Certificat No.	TÜV 13 ATEX 7439X - IECEx TUR 13.0012X
Standards	IEC 60079-0, IEC 60079-7, IEC 60079-11, IEC 60079-31
Material	A) Stainless steel B) Painted mild steel
Finish	Stainless steel may be coated or painted to suit customer application Mild steel may be coated or painted to suit customer application
Ingress protection	IP 66 to IEC 60529
Temperature class	T6 / T5 / T4
Ambient temperature	-30°C to 55°C / -20°C to 40°C
lid fixing	Hinged by 4xM6 Stainless steel screws
Earthing	M10 Internal / External stainless steel stud
Enclosure mounting	4 slotted fixing brackets for M10 screws
Drain plug	M20 breather/drain plug as an option
Entries	Through gland plates or through walls

CABLE ENTRY SELECTION

THREAD SIZE	M20(O)	M20(A)	M25(B)	M32(C)	M40(C2)	M50(D)	M63(E)	M75(F)	M90	
ACROSS FLATS	25	30	36	46	55	65	80	95	-	
ACROSS CORNERS	27.7	34.6	41.6	53.1	63.5	75.1	92.4	109.7	-	
Height	L R									
MAX.NO. OF ENTRIES	140	14 (27)	6 (14)	5 (12)	4 (5)	- (4)	- (3)	- (2)	- -	- -
		T B	8 (18)	3 (10)	3 (8)	2 (3)	- (2)	- (6)	- (1)	- (1)
Height	L R									
MAX.NO. OF ENTRIES	200	28 (45)	18 (28)	15 (18)	8 (10)	6 (8)	3 (2)	2 (2)	2 -	- -
		T B	16 (30)	9 (16)	6 (12)	4 (6)	2 (4)	1 (4)	1 (1)	1 (2)

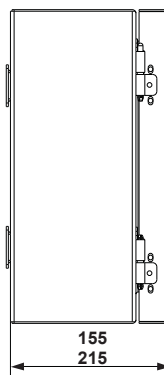
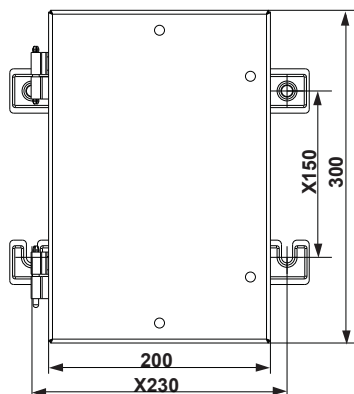

* Values in brackets are valid when no gland plate is installed

** The number of entries indicated above is for reference only, and may vary depend on application requirement e.g.: type of cable entries , number of terminals , ...

***Dimensions in mm

All information may be revised or changed by SHOMAL at anytime without prior notice or explanation.



JUNCTION BOX

Supreme SERIES

SPM 2



Zone 1,2,21,22

SPM 2 TERMINAL CAPACITY DATA

TERMINAL TYPE	CONDUCTOR SIZE mm ²		MAX NO OF TERMINALS		MAX NO OF RAILS	
	MIN	MAX	PER RAIL	TOTAL		
WDU 1.5/ZZ*	0.13	2.5	31	31	1	VERTICAL
			11	22	2	HORIZONTAL
WDU 2.5 / 1.5/ ZR	0.13	4	31	31	1	VERTICAL
			11	22	2	HORIZONTAL
WDU 2.5	0.13	4	31	31	1	VERTICAL
			11	22	2	HORIZONTAL
WDU 2.5N	0.13	4	31	31	1	VERTICAL
			11	22	2	HORIZONTAL
WDU 4	0.13	6	26	26	1	VERTICAL
			9	18	2	HORIZONTAL
WDU 6	0.5	10	20	20	1	VERTICAL
			7	14	2	HORIZONTAL
WDU 10	1.31	16	16	16	1	VERTICAL
			5	10	2	HORIZONTAL
WDU 16	1.5	25	13	13	1	VERTICAL
			4	8	2	HORIZONTAL
WDU 35	2.5	50	10	10	1	VERTICAL
			3	6	2	HORIZONTAL
WDU 50N	5.26	70	8	8	1	VERTICAL
			8	8	1	HORIZONTAL
WDU 70/95	16	120	6	6	1	VERTICAL
			6	6	1	HORIZONTAL
WDK2.5*	0.13	4	31	31	1	VERTICAL
			11	22	2	HORIZONTAL
WFF35*	2.5	50	6	6	1	VERTICAL
			2	2	1	HORIZONTAL
SAK 2.5*	0.5	4	27	27	1	VERTICAL
			9	18	2	HORIZONTAL
SAK 4	0.5	6	24	24	1	VERTICAL
			8	16	2	HORIZONTAL
SAK 6N	0.5	10	20	20	1	VERTICAL
			7	14	2	HORIZONTAL
SAK 10	1.5	16	16	16	1	VERTICAL
			5	10	2	HORIZONTAL
SAK 16	2.5	16	13	13	1	VERTICAL
			4	8	2	HORIZONTAL
SAK 35	6	50	9	9	1	VERTICAL
			3	6	2	HORIZONTAL
ZDU 2.5*	0.08	4	31	31	1	VERTICAL
			11	22	2	HORIZONTAL
ZDU2.5/3AN	0.08	4	31	31	1	VERTICAL
			11	22	2	HORIZONTAL
ZDU2.5/4AN	0.08	4	31	31	1	VERTICAL
			11	22	2	HORIZONTAL
ZDU2.5/2x2AN	0.08	4	31	31	1	VERTICAL
			11	22	2	HORIZONTAL
ZDU 4	0.21	6	27	27	1	VERTICAL
			9	18	2	HORIZONTAL
ZDU 6	0.21	6	20	20	1	VERTICAL
			7	14	2	HORIZONTAL
ZDK2.5/1.5*	0.08	2.5	31	31	1	VERTICAL
			11	22	2	HORIZONTAL
UK 1.5N**	0.14	0.7	38	38	1	VERTICAL
			13	26	2	HORIZONTAL
UK 2.5N	0.2	2.5	31	31	1	VERTICAL
			11	22	2	HORIZONTAL

All information may be revised or changed by SHOMAL at anytime without prior notice or explanation.

JUNCTION BOX

Supreme SERIES
SPM 2



Zone 1,2,21,22



SPM 2 TERMINAL CAPACITY DATA (Continued)

TERMINAL TYPE	CONDUCTOR SIZE mm ²		MAX NO OF TERMINALS		MAX NO OF RAILS	
	MIN	MAX	PER RAIL	TOTAL		
UK 3N	0.2	2.5	31	31	1	VERTICAL
			11	22	2	HORIZONTAL
UK 5N	0.2	4	26	26	1	VERTICAL
			9	18	2	HORIZONTAL
UK 6N	0.2	6	19	19	1	VERTICAL
			7	14	2	HORIZONTAL
UK 10N	0.5	10	15	15	1	VERTICAL
			5	10	2	HORIZONTAL
UK 16N	0.75	16	13	13	1	VERTICAL
			4	8	2	HORIZONTAL
UK 35	0.75	35	10	10	1	VERTICAL
			3	6	2	HORIZONTAL
RTP 2.5***	0.5	4	27	27	1	VERTICAL
			9	18	2	HORIZONTAL
RTP 4	0.5	4	25	25	1	VERTICAL
			9	18	2	HORIZONTAL
RTP 6	0.5	10	20	20	1	VERTICAL
			7	14	2	HORIZONTAL
RTP 10	0.5	16	16	16	1	VERTICAL
			5	10	2	HORIZONTAL
RTP 16	0.5	16	12	12	1	VERTICAL
			4	8	2	HORIZONTAL
RTP 25	0.5	25	11	11	1	VERTICAL
			4	8	2	HORIZONTAL
RTP 35	1.5	35	24	24	1	VERTICAL
			8	16	2	HORIZONTAL
RTP 95	6	95	6	6	1	VERTICAL
			6	6	1	HORIZONTAL
WFF 70	2.5	95	5	5	1	VERTICAL
			5	5	1	HORIZONTAL

* SAK & WDU & WDK & ZDU & ZDK & WFF ARE WEIDMULLER / KLIPPON RANGE OF TERMINALS.

** UK & UKH ARE PHOENIX CONTACT RANGE OF TERMINALS.

*** RTP IS RAAD RANGE OF TERMINALS.

ALL TERMINALS INCREASED SAFETY AND ALL CODED Exe II.

NOTES

- 1- THE NUMBER AND COMBINATION OF DIFFERENT SIZES OF TERMINALS WHICH CAN BE FITTED TO THE ENCLOSURE IS LIMITED BY THE MAXIMUM POWER DISSIPATION OF ENCLOSURE FOR ASSISTANCE CALL THE " S.E.M.C. " REPRESENTATIVE.
- 2- ROWS OF TERMINALS ARE FITTED BETWEEN END STOPS ON TERMINALS RAILS.
- 3- PARTITIONS ARE FITTED BETWEEN TERMINALS OF DIFFERENT TYPES OR SIZES, AND BETWEEN LINKED AND UNLINKED TERMINALS.
- 4- THE TABLE SHOWN IS GIVEN AS A GUIDE ONLY, ALLOWANCE HAVE BEEN MADE FOR THE FITTING OF ONE END SECTION AND TWO END BRACKETS ON EACH RAIL.
- 5- THE NUMBER OF TERMINALS MUST BE REDUCED IF PARTITIONS OR EXTRA END SECTION SPACE ARE REQUIRED.

All information may be revised or changed by SHOMAL at anytime without prior notice or explanation.